

GNH1200TN

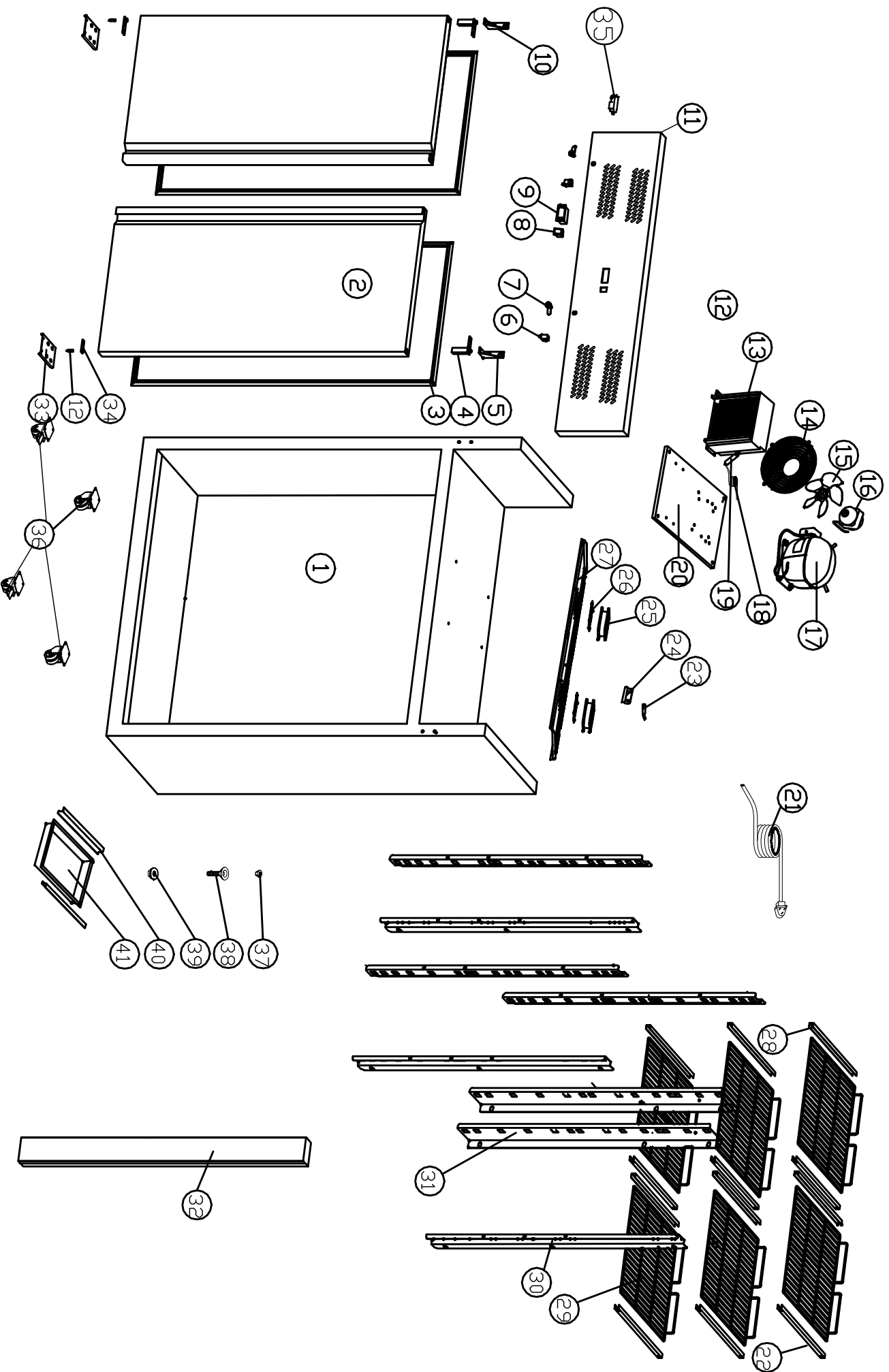

GNH1200TN SPARE PARTS LIST

	CODE	CODE L2G	Name	Désignation	DESCRIPTION	UNIT	QTY	REMARK
1	SKC-0-000-0336-0	#N/A	BODY	CORPS		SET	1	
2	SKC-0-000-1258-0	GN1200TN.02	DOOR	PORTE		SET	2	
3	SKC-2-110-0072-0	GN1200TN.03	GASKET	JOINT DE PORTE	PVC	PC	2	
4	SKC-2-160-0600-0	GN1200TN.04	DOOR SPRING	RESSORT DE PORTE		PC	2	
5	SKC-2-001-0153-0	GN1200TN.05	UP HINGE/RIGHT	CHARNIERE HAUTE DROITE	201#	PC	1	
6	SKC-4-050-0005-0	GN1200TN.06	DOOR SWITCH	BOUTON DE PORTE		PC	2	
7	SKC-2-170-0081-0	GN1200TN.07	LOCK	SERRURE		PC	2	
8	SKC-4-050-0001-0	GE800BT-6	MAIN SWITCH	BOUTON M/A		PC	1	
9	SKC-4-030-0017-0	XR02CX	thermostat	THERMOSTAT	DIXELL 02	PC	1	
10	SKC-2-001-1056-0	GN1200TN.10	top hinge left	CHARNIERE HAUTE GAUCHE	201#	PC	1	
11	SKC-2-002-0755-0	#N/A	FRONT PANEL	PANNEAU FRONTAL		PC	1	
12	SKC-2-170-0211-0	BBT350L.31	HING AXIS	AXE DE CHARNIERE	304#	PC	2	
13	SKC-2-102-0049-0	PGN1200TN.13	CONDENSOR	CONDENSEUR		PC	1	
14	SKC-2-120-0041-0	#N/A	BASKET GUARD GRILLS	GRILLE DE PROTECTION VENTILATEUR		PC	1	
15	SKC-2-105-0001-0	#N/A	CONDENSOR FAN BLADE	HELICE DE VENTILATEUR DE CONDENSEUR		PC	1	
16	SKC-4-001-0004-0	#N/A	CONDENSOR FAN	VENTILATEUR DE CONDENSEUR	EBM 7W	PC	1	
17	SKC-4-040-0203-0	PS903.03	COMPRESSOR	COMPRESSEUR	EMBRACO	PC	1	
18	SKC-2-104-0165-0	PS900.43	CAPILLARY	CAPILAIRE		PC	1	
19	SKC-2-103-0001-0	GN1200TN.19	FILTER DRIER	DESHYDRATEUR		PC	1	
20	SKC-2-001-0126-0	GN1200TN.20	UNIT BOARD	SUPPORT GROUPE		PC	1	
21	SKC-4-010-0080-0	#N/A	power core	CABLE ELECTRIQUE	EU	PC	1	
22	SKC-2-002-0919-0	GN1200TN.28	GUIDE RAIL	GLISSIERE	201#	PC	6	
23	SKC-4-030-0006-0	GE800BT-29	SENSOR	SONDE		PC	1	
24	SKC-2-002-0036-0	BBT350L.50	PROBE PADDING	SUPPORT SONDE		PC	1	
25	SKC-4-001-0026-0	BBT350L.47	CIRCLE FAN	VENTILATEUR	4C-230HB	PC	2	
26	SKC-2-120-0043-0	BBT350L.46	FAN GUARD	PROTECTION DE VENTILATEUR		PC	2	
27	SKC-2-002-6010-0	GN1200TN.27	Air conduct	CONDUIT D'AIR	201#	PC	1	
28	SKC-2-001-0062-0	GN1200TN.28	GUIDE RAIL	GLISSIERE	201#	PC	6	

GNH1200TN SPARE PARTS LIST

	CODE	CODE L2G	Name	Désignation	DESCRIPTION	UNIT	QTY	REMARK
29	SKC-2-120-0005-0	GN1200TN.29	SHELF	ETAGERE		PC	6	
30	SKC-2-001-0019-0	GN1200TN.30	FRONT SUPPORT/LEFT	MONTANT VERTICAL GAUCHE	201#	PC	6	
31	SKC-2-001-0022-0	GN1200TN.31	back support	MONTANT VERTICAL ARRIERE	201#	PC	2	
32	SKC-0-000-0339-0	GN1200TN.32	mullion	MONTANT CENTRAL		PC	1	
33	SKC-2-001-0385-0	GN1200TN.45	DOWN HINGE/RIGHT	CHARNIERE BASSE DROITE	201#	PC	2	
34	SKC-2-110-0353-0	GN1200TN.43	SHAFT SLEEVE	MANCHON		PC	2	
35	SKC-4-050-0056-0	GN1200TN.35	LED light	LED		PC	2	
36	SKC-2-140-0005-0	#N/A	castor with brake	ROULETTE AVEC FREIN		PC	2	
36	SKC-2-140-0004-0	#N/A	castor without brake	ROULETTE SANS FREIN		PC	2	
37	SKC-2-110-0318-0	GN1200TN.37	drain pipe cover	BOUCHON DE TUYAU D'EVACUATION	ABS	PC	1	
38	SKC-2-110-0316-0	GN1200TN.38	drain pipe	TUYAU D'EVACUATION	ABS	PC	1	
39	SKC-2-110-0317-0	GN1200TN.39	drain pipe nut	ECROU DE TUYAU D'EVACUATION	ABS	PC	1	
40	SKC-2-001-0252-0	GN1200TN.40	WATER PAN GUIDE/	SUPPORT BAC A EAU		PC	2	
41	SKC-2-110-0347-0	GN1200TN.41	WATER BOX	BAC A EAU		PC	1	